

CONCRETE FOOTPATH REPAIR (RESIDENTIAL) NOTES:

1. FOOTPATH REPAIR WIDTH TO MATCH EXISTING FOOTPATH WIDTH.
2. ALL CONCRETE FOOTPATHS TO BE NON-SLIP (BRUSH FINISHED).
3. WHERE AN EXPOSED AGGREGATE SURFACE FINISH IS REQUIRED, REFER TO COUNCIL'S REPRESENTATIVE FOR AGGREGATE TYPE & COLOUR.
4. 'TOOLED' CONTRACTION JOINTS TO BE PROVIDED @ 1200c/c MAX. SPACING. JOINTS ARE ALSO TO BE PROVIDED AT DRIVEWAY EDGES AND BETWEEN THE FOOTPATH AND ANY ADDITIONAL CONCRETE REQUESTED.
5. FULL DEPTH EXPANSION JOINTS TO BE PROVIDED @ 6.0m MAX. SPACING. JOINTS TO BE EITHER 20mm WIDE AND FILLED WITH BITUMEN IMPREGNATED 'CANITE' OR SIMILAR APPROVED WITH N12 DOWELS x 300 LONG, EMBEDDED 150mm INTO CONCRETE WITH END CAP @ 300c/c **OR** 'DANLEY'S EXPANDA JOINT' BY DANLEY SYSTEMS OR SIMILAR APPROVED, INSTALLED IN ACCORDANCE WITH THE MANUFACTURER'S SPECIFICATIONS.
6. CONCRETE TO BE 32MPa UNLESS NOTED OTHERWISE.
7. 'TRIP STOP' TO BE INSTALLED AT NO GREATER THAN 1500c/c SPACINGS WHERE LONGER LENGTHS OF FOOTPATH REPAIR ARE REQUIRED.
8. 100mm PM2/20 BASE TO BE USED AT DRIVEWAY CROSSOVERS AND ANY AREAS SUBJECT TO VEHICULAR LOADING.
9. FOR BACKFILLING OF DRAINAGE OR SERVICE TRENCHES BELOW FOOTPATH BASE LEVEL REFER TO SD-432 & SD-433.

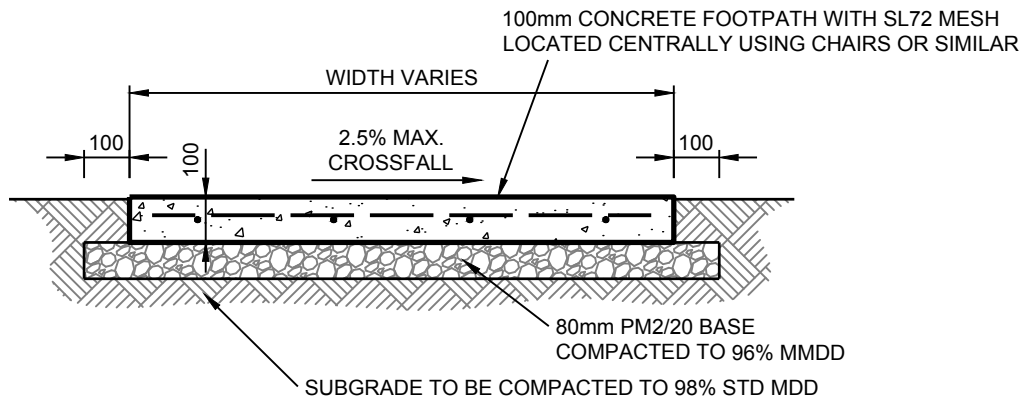

CROSS SECTION

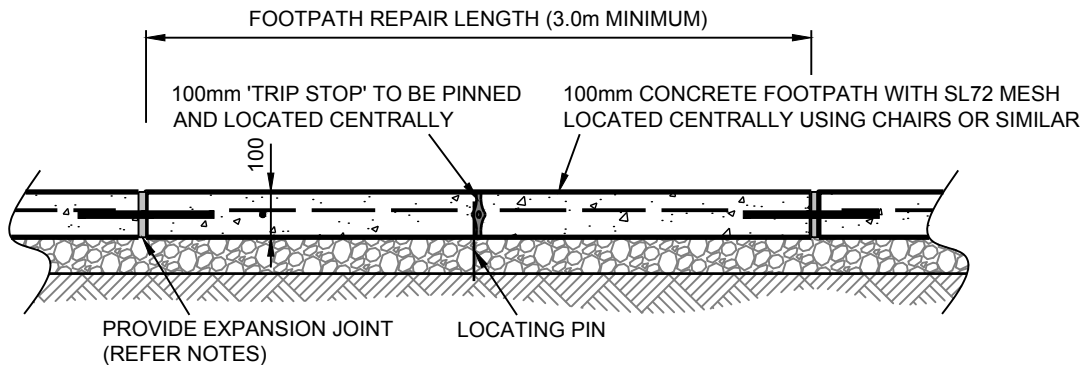

LONGITUDINAL SECTION VIEW

CONCRETE FOOTPATH REPAIR (SD-340)

(RESIDENTIAL)

NOT TO SCALE

1. All dimensions are in millimeters unless otherwise shown.
2. It is the responsibility of the individual to ensure that they are using the current version of this drawing. Council accepts no liability for issues arising from the use of superseded drawings. Printed copies of this drawing are uncontrolled.

REV	DESCRIPTION	APPROVED	DATE	APPROVED TEAM LEADER TECHNICAL SERVICES	CONCRETE FOOTPATH REPAIR (RESIDENTIAL)	STANDARD # SD-340	REV A
A	ORIGINAL ISSUE	C.HASKAS	FEB '18	<i>Urris Haskas</i> SCALE AT A4 NOT TO SCALE			